

MIL-STD-188-124A
2 FEBRUARY 1984
SUPERSEDING
MIL-STD-188-124
14 JUNE 1978

MILITARY STANDARD

GROUNDING, BONDING AND SHIELDING

for Common
Long Haul/Tactical Communication Systems
Including Ground Based Communications-
Electronics Facilities and Equipments



NO DELIVERABLE DATA REQUIRED BY THIS DOCUMENT

EMCS/SLHC/TCTS

MIL-STD-188-124A
2 FEBRUARY 1984

DEPARTMENT OF DEFENSE

Washington, D.C. 20301

GROUNDING, BONDING AND SHIELDING

MIL-STD-188-124

1. This Military Standard is approved and mandatory for use by all Departments and Agencies of the Department of Defense in accordance with OASD (C³I) Memo (see Appendix A).
2. Beneficial comments (recommendations, additions, deletions) and any pertinent data which may be of use in improving this document should be addressed to: Commander; 1842 EEG/EEITE, Scott AFB IL 62225, by using the self-addressed Standardization Document Improvement Proposal (DD Form 1426) appearing at the end of this document or by letter.

FOREWORD

1. Standards for all military communications are published as part of a MIL-STD-188 series of documents: Military Communications System Technical Standards are subdivided into Common Long Haul/Tactical Standards (MIL-STD-188-100 series), Tactical Standards (MIL-STD-188-200 series) and Long Haul Standards (MIL-STD-188-300 series).
2. This document contains technical standards and design objectives to ensure the optimum performance of ground-based telecommunications C-E equipment installations. This is accomplished by reducing noise and by providing adequate protection against power system faults and lightning strikes. Thorough consideration must be given to the grounding of equipment and facility installations, the bonding required, and the methods of shielding and implementation needed for personnel safety and equipment control.
3. This standard is also recommended for applicable use on any ground facility or equipment where grounding, bonding, shielding, personnel safety, lightning and EMC are required. Examples of such facilities are aircraft simulators, computer centers, laboratory buildings, weapons checkout and assembly, etc.
4. Paragraph 5.1, Grounding, for this standard is divided as follows:
 - I. Detailed requirements for facilities, including buildings and associated structures used principally for C-E equipment.
 - II. Detailed requirements for C-E equipment which address grounding, bonding, and shielding for tactical/long haul fixed ground transportables and military communications electronics equipment installations and associated subsystems.
5. Detailed requirements for Bonding and Shielding are contained in 5.2 and 5.3.
6. This standard is further implemented by MIL-HDBK-419; Grounding, Bonding, and Shielding for Electronic Facilities and Equipments.
7. Asterisks or vertical lines are not used in this revision to identify changes with respect to the previous issue due to the extensiveness of the changes.

CONTENTS

	<u>Page</u>
Paragraph 1.	SCOPE 1
1.1	Purpose 1
1.2	Content 1
1.3	Applications 1
1.4	Objectives 1
1.5	System Standards and Design Objectives 1
2.	REFERENCED DOCUMENTS 2
2.1	Government Documents 2
2.1.1	Specifications, Standards, and Handbooks 2
2.1.2	Other Government Documents, Drawings, and Publications 2
2.2	Other Publications 3
2.3	Source of Documents 3
2.4	Order of Precedence 3
3.	DEFINITIONS 4
4.	GENERAL REQUIREMENTS 5
4.1	General 5
4.2	Grounding 5
4.2.1	General 5
4.2.2	Tactical Equipments and Facilities 5
4.3	Bonding 5
4.3.1	General 5
4.4	Shielding 5
4.4.1	General 5
5.	DETAILED REQUIREMENTS 6
5.1	Grounding 6
5.1.1	Building and Structure 6
5.1.1.1	Earth Electrode Subsystem 6
5.1.1.1.1	General 6
5.1.1.1.2	Earth Resistivity Survey.. . . . 6
5.1.1.1.3	Minimum Configuration 6
5.1.1.1.3.1	Resistance to Earth 6
5.1.1.1.3.2	Additional Considerations 6
5.1.1.1.4	Ground Rods 6
5.1.1.1.5	Connecting Risers. 6
5.1.1.1.6	Other Underground Metals 6
5.1.1.1.7	Resistance Checks 11
5.1.1.2	Fault Protection Subsystem 11
5.1.1.2.1	General 11
5.1.1.2.2	Building Structural Steel 11
5.1.1.2.3	Pipes and Tubes. 11
5.1.1.2.4	Electrical Supporting Structures 11
5.1.1.2.4.1	Conduit 11
5.1.1.2.4.2	Cable Trays or Raceways 11
5.1.1.2.4.3	Wiring System Enclosures 11
5.1.1.2.4.4	Metallic Power Cable Sheaths 11
5.1.1.2.5	Electrical Power Systems 12
5.1.1.2.5.1	AC Distribution Systems 12
5.1.1.2.5.1.1	Single Building with Multipower Sources 12
5.1.1.2.5.1.2	Multibuildings with Single Power Source 12
5.1.1.2.5.2	Standby AC Generators 12
5.1.1.2.5.3	AC Outlets. 12
5.1.1.2.5.4	Electrical Motors and Generators 12
5.1.1.2.5.5	DC Power Sources 12
5.1.1.2.5.6	Metallic Battery Racks 12
5.1.1.2.5.7	Ground Fault Circuit Interrupters 12
5.1.1.2.6	Secure Facilities 12

CONTENTS - Continued

	<u>Page</u>	
5.1.1.3	Lightning Protection Subsystem	12
5.1.1.3.1	General	12
5.1.1.3.2	Buildings and Structures	12
5.1.1.3.3	Down Conductors	13
5.1.1.3.4	Bonding	13
5.1.1.3.5	Structural Steel	13
5.1.1.3.6	Air Terminals (Lightning Rods)	13
5.1.1.3.7	Guards	13
5.1.1.3.8	Supporting Structures (Towers)	13
5.1.1.3.8.1	Earth Electrode Subsystem	13
5.1.1.3.8.2	Air Terminals	13
5.1.1.3.8.3	Down Conductors	13
5.1.1.3.8.4	Waveguide Grounding	14
5.1.1.3.9	Exterior Nonstructural Metal Elements	14
5.1.1.3.10	Exterior Wires and Cables	14
5.1.1.3.10.1	Conduit	14
5.1.1.3.10.2	Overhead Guard Wires	14
5.1.1.3.11	Underground Guard Wires	14
5.1.1.3.12	Lightning Arrestors	14
5.1.1.3.13	Security/Perimeter Fences	14
5.1.1.4	Signal Reference Subsystem	15
5.1.1.4.1	General	15
5.1.1.4.2	Higher Frequency Network	15
5.1.1.4.3	Lower Frequency Network	15
5.1.2	Communications-Electronics (C-E) Equipment	15
5.1.2.1	Signal Reference Subsystem	15
5.1.2.1.1	Higher Frequency Network	15
5.1.2.1.1.1	Signal Isolation	15
5.1.2.1.1.2	Equipment Signal Ground Terminations	15
5.1.2.1.1.3	Shield Terminations on Coaxial and Other Higher Frequency Cables	15
5.1.2.1.1.4	Overall Shields	15
5.1.2.2	Fault Protection Subsystem	17
5.1.2.2.1	General	17
5.1.2.2.2	Personnel Protection	17
5.1.2.2.3	AC Power Neutral	17
5.1.2.2.4	Individual Power Line Filters	17
5.1.2.2.5	Convenience Outlets	17
5.1.2.2.6	Portable Equipment	17
5.2	Bonding	18
5.2.1	General	18
5.2.2	Surface Platings or Treatments	18
5.2.3	Bond Protection	18
5.2.3.1	Corrosion Protection	18
5.2.3.2	Compression Bonds in Protected Areas	18
5.2.3.3	Vibration	18
5.2.3.3.1	Bonding Straps	18
5.2.4	Bond Resistance	18
5.2.5	Materials	18
5.2.5.1	Sweat Solder	18
5.2.5.2	Brazing Solder	18
5.2.5.3	Clamps	19
5.2.5.4	Nuts, Bolts, and Washers	19
5.2.6	Direct Bonds	19
5.2.6.1	Welding	19
5.2.6.2	Brazing and Silver Soldering	19
5.2.6.3	Bonding of Copper to Steel	19
5.2.6.4	Soft Soldering	19
5.2.6.4.1	Sweat Soldering	19
5.2.6.4.2	Sheet Metal or Duct Work	19
5.2.6.5	Bolting	19
5.2.6.6	C-Clamps and Spring Clamps	19

CONTENTS - Continued

	<u>Page</u>	
5.2.7	Indirect Bonds	20
5.2.8	Surface Preparation	20
5.2.8.1	Area to be Cleaned	20
5.2.8.2	Paint Removal	20
5.2.8.3	Inorganic Film Removal	20
5.2.8.4	Final Cleaning	20
5.2.8.4.1	Clad Metals	20
5.2.8.4.2	Aluminum Alloy	20
5.2.8.5	Completion of the Bond	20
5.2.9	Dissimilar Metal	20
5.2.9.1	Corrosion Prevention	20
5.2.10	Enclosure Bonding	20
5.2.10.1	Subassemblies	20
5.2.10.2	Equipments	20
5.2.11	Connector Mounting	20
5.2.12	Shield Terminations	20
5.2.13	RF Gaskets	21
5.3	Shielding	21
5.3.1	General	21
5.3.1.1	Basic Shielding Requirements	21
5.3.1.2	Shielded Enclosures	21
5.3.2	Electromagnetic Interference (EMI) Control	21
5.3.2.1	Materials	21
5.3.2.2	Gaskets	21
5.3.2.3	Filter Integration	21
5.3.2.4	Control of Apertures	22
5.3.2.5	Wire and Cable Routing	22
5.3.2.6	Telephone Cable Shields	22
APPENDIX A - Mandatory Use of Military Standards in the 188 Series		24
APPENDIX B - Discussion of Signal Ground Systems		26
Paragraph 1.	General	26
1.1	Single Point Ground System	26
1.2	Equipotential Ground System	26
1.2.1	Equipotential Plane	27
1.2.2	Types of Equal Potential Planes	27

FIGURES

	<u>Page</u>	
Figure 1	Example of Equipotential or Multipoint Grounding to Earth Electrode Subsystem for Overhead Plane	7
2	Example of Equipotential Plane to Earth Electrode Subsystem (for New Construction)	8
3	Typical Single Point Entry for Exterior Penetrations (Top View)	9
4	Typical Entry Plate Showing Rigid Cable, Conduit and Pipe Penetrations	10
5	Typical Equipotential Ground Plane for New Construction Higher Frequency Facilities Installation	16

1. SCOPE

1.1 Purpose. This standard establishes the minimum basic requirements and goals for grounding, bonding, and shielding of ground-based telecommunications C-E equipment installations, subsystems, and facilities including buildings and structures supporting tactical and long haul military communication systems.

1.2 Content. This standard addresses the facilities ground systems, as well as grounding, bonding, and shielding for telecommunications C-E facilities and equipments. Grounding for building and structures is listed under the headings of Earth Electrode Subsystem, Fault Protection Subsystem, Lightning Protection Subsystem and Signal Reference Subsystem.

1.3 Applications. This standard shall be used in the design and engineering of new ground-based military communication systems, subsystems, and equipment installations and may be used with any ground-based facility, system, or equipment installation. This includes air traffic control and navigational aid facilities, radio, satellite ground terminals, telephone central offices, microwave and data communications systems, as well as C-E transportables, aircraft simulators, computer centers, and weapons assembly facilities. Use of this standard for other ground C-E facilities or equipment is also encouraged. It is not to be used solely as a basis for retrofit of existing C-E facilities. It does not apply to general construction such as barracks, administration buildings, dining facilities, warehouses, and non-communications facilities, nor does it apply to mobile units such as tanks, trucks, jeeps, etc.

1.4 Objectives. The objectives of this standard are to reduce noise and electromagnetic interference caused by inadequate grounding, bonding, and shielding of ground-based military communications installations to acceptable performance levels. It also provides for the protection of personnel, equipment, buildings, and structures against the hazards posed by electrical power faults and lightning strikes. It shall be required that the grounding, bonding, and shielding system be engineered to be compatible with the supplemental requirements of the specific equipment or facility supporting these communications.

1.5 System Standards and Design Objectives. The parameters and other requirements specified in this document are mandatory system standards if the word "shall" is used in connection with the parameter value or requirement under consideration. Non-mandatory design objectives are indicated by parentheses after a standardized parameter value or by the word "should" in connection with the parameter value or requirement under consideration. For a definition of the terms "system standard" and "design objective" (DO), see FED-STD-1037.

MIL-STD-188-124A
2 FEBRUARY 1984

2. REFERENCED DOCUMENTS

2.1 Government Documents.

2.1.1 Specifications, Standards, and Handbooks. Unless otherwise specified, the following specifications, standards, and handbooks of the issue listed in that issue of the Department of Defense Index of Specifications and Standards (DODISS) specified in a solicitation form a part of this standard to the extent specified herein.

SPECIFICATIONS

FEDERAL

- P-D-680 - Dry Cleaning Solvent
- TT-P-1757 - Primer Coating, Zinc Chromate, Low Moisture Sensitivity

STANDARDS

FEDERAL

- FED-STD-1037 - Glossary of Telecommunication Terms

MILITARY

- AN-735 - Clamp, Loop Type Bonding
- AN-742 - Clamp, Plain, Support, Loop-Type, Aircraft
- MIL-STD-285 - Attenuation Measurement for Enclosures, Electromagnetic Shielding, for Electronic Test Purposes, Method of
- MIL-STD-454 - General Requirements for Electronic Equipment
- MIL-STD-461 - Electromagnetic Emission and Susceptibility Requirements for the Control of Electromagnetic Interference
- MIL-STD-462 - Electromagnetic Interference Characteristics, Measurement of
- MIL-STD-463 - Definitions and Systems of Units, Electromagnetic Interference and Electromagnetic Compatibility Technology
- MIL-STD-1857 - Grounding, Bonding and Shielding Design Practices
- MS-25083 - Jumper Assembly, Electric, Bonding and Current Return

HANDBOOK

MILITARY

- MIL-HDBK-419 - Grounding, Bonding, and Shielding for Electronic Equipments and Facilities

2.1.2 Other Government Documents, Drawings, and Publications. The following other Government documents, drawings, and publications form a part of this standard to the extent specified herein.

- DOD Directive 1000.3 - Safety and Occupational Health Policy for the Department of Defense
- NACSIM 5203(C) - Guidelines for Facility Design and RED/BLACK Installation(U)
- NACSEM 5204(C) - Shielded Enclosures(U)

(Copies of specifications, standards, handbooks, drawings, and publications required by contractors in connection with specific acquisition functions should be obtained from the contracting activity or as directed by the contracting officer.)

2.2 Other Publications. The following document(s) form a part of this standard to the extent specified herein. The issues of the documents which are indicated as DOD adopted shall be the issue listed in the current DODISS and the supplement thereto, if applicable.

AMERICAN INSTITUTE OF STEEL CONSTRUCTION (AISC)

AISC S326 - Specification for the Design, Fabrication and Erection of Structural Steel for Buildings, Section 1.17.2

(Application for copies of the AISC specification should be addressed to the American Institute of Steel Construction, Inc., P.O. Box 4588, Chicago, Illinois 60680.)

AMERICAN SOCIETY FOR TESTING AND MATERIALS (ASTM)

ANSI/ASTM B 32 - Solder Metal, Specification for (DOD adopted)

(Application for the ASTM document should be addressed to the American Society for Testing and Materials, 1916 Race Street, Philadelphia, PA 19103.)

AMERICAN WELDING SOCIETY (AWS)

AWS A 5.8 - Brazing Filler Metal, Specification for (DOD adopted)

(Application for the AWS specification should be addressed to the American Welding Society, 550 Northwest Lejeune Road, P.O. Box 351040, Miami, Florida 33135.)

NATIONAL FIRE PROTECTION ASSOCIATION (NFPA)

NFPA No. 70 - National Electrical Code (DOD adopted)

NFPA No. 78 - Lightning Protection Code

(Application for NFPA-70 or 78 should be addressed to the National Fire Protection Association, 470 Atlantic Avenue, Boston, MA 02210.)

(Industry association specifications and standards are generally available for reference from libraries. They are also distributed among technical groups and using Federal agencies.)

2.3 Source of Documents. Copies of Federal and military standards, specifications, and associated documents listed in the Department of Defense Index of Specifications and Standards (DODISS), should be obtained from the DOD Single Stock Point, Commanding Officer, Naval Publications and Forms Center, 5801 Tabor Avenue, Philadelphia, PA 19120. Single copies may be obtained on emergency basis by calling (AUTOVON) 442-3321 or Area Code (215) 697 3321. Copies of industry association documents should be obtained from the sponsor. Copies of all other listed documents should be obtained from the contracting activity or as directed by the contracting officer.

2.4 Order of Precedence. In the event of a conflict between the text of this standard and the references cited herein, the text of this standard shall take precedence.

MIL-STD-188-124A
2 FEBRUARY 1984

3. DEFINITIONS

For military communications definitions, see FED-STD-1037. Terms related to EMC documents can be found in MIL-STD-463.

- C-E - Communications-Electronics
- NACSEM - National COMSEC/EMSEC Information Memorandum
- NACSIM - National COMSEC Information Memoranda

4. GENERAL REQUIREMENTS

4.1 General. The need exists for effecting grounding, bonding, and shielding of (1) electrical/electronic equipments and (2) buildings and structures (facilities) in order to achieve improved equipment operating efficiencies and increased safety practices. These requirements include the reduction of electromagnetic interference (EMI) and noise by the proper grounding, bonding, and shielding of C-E facilities and equipments. This requirement also is intended to protect personnel from hazardous voltages due to electrical power faults, lightning strikes, and high level electromagnetic radiations associated with normal equipment operation and maintenance. The facility ground system forms a direct path of known low impedance between earth and the various power and communication equipments. This effectively minimizes voltage differentials on the ground plane which exceed a value that will produce noise or interference to communication circuits. Personnel and equipment protection is afforded when, during an occurrence of an electrical ground fault, the ground system provides a path for rapid operation of protective overcurrent devices; or, during a lightning stroke, provides a low impedance path for current to earth. Personnel and equipment protection against power fault currents, static charge buildup and lightning flashover shall be provided both by protective ground wires and by bonding all normally non-current carrying metal objects, including structural steel support members, to the facility ground system. This ground system also provides low impedance paths between various buildings and structures of the facility, as well as between equipments within the facility, to earth in order to minimize the effects of noise currents. For additional information refer to the supporting document MIL-HDBK-419.

4.2 Grounding.

4.2.1 General. The facility ground system consists of the following electrically interconnected subsystems:

- a. The earth electrode subsystem, including the various interconnected metallic elements such as buried fuel tanks, tower bases, fences, water pipes, etc.
- b. The equipment fault protection subsystem.
- c. The lightning protection subsystem.
- d. The signal reference subsystem.

These items, in their entirety, compose the total ground system for the facility (See 5.1 and Appendix B).

4.2.2 Tactical Equipments and Facilities. The grounding, bonding, and shielding requirements for tactical equipments and facilities are similar in concept to those for fixed C-E facilities. For specific applications, see MIL-HDBK-419.

4.3 Bonding.

4.3.1 General. A bond is an electrical union between two metallic surfaces used to provide a low-impedance path between them. Bonding is the procedure by which the conductive surface of a subassembly or component is electrically connected to another. This prevents development of electrical potentials between individual metal surfaces for all frequencies capable of causing interference. (See 5.2).

4.4 Shielding.

4.4.1 General. Shielding is required in electrical and electronic equipments to prevent the equipment from propagating interference and to protect the equipment from the effects of interference propagated by other electronic devices. (See 5.3). For individual equipment requirements, see MIL-STD-461 and MIL-STD-1857. For test procedures, see MIL-STD-462 and MIL-STD-285 (for shielded enclosures); for EMC definitions, see MIL-STD-463.

MIL-STD-188-124A
2 FEBRUARY 1984

5. DETAILED REQUIREMENTS

5.1 Grounding. The facility ground system consists of four electrically connected subsystems. These are:

- a. Earth electrode subsystem.
- b. Fault protection subsystem.
- c. Lightning protection subsystem.
- d. Signal reference subsystem.

These subsystems compose the Facility Ground System and are addressed in detail in the following sections.

5.1.1 Building and Structure.

5.1.1.1 Earth Electrode Subsystem.

5.1.1.1.1 General. An earth electrode subsystem shall be installed at each C-E facility to provide a low resistance path to earth for lightning and power fault currents and ensure that hazardous voltages do not occur within the facility. This subsystem shall be capable of dissipating to earth the energy of direct lightning strokes with no ensuing degradation to itself. This system shall also interconnect all driven electrodes and underground metal objects of the C-E facility. The earth electrode subsystem shall not degrade the quality of signals in the signal circuits connected to it. For more details regarding installation practices, see MIL-HDBK-419.

5.1.1.1.2 Earth Resistivity Survey. The design agency shall conduct an earth resistivity survey at the site before construction is begun. The values of earth resistivities characterizing the site shall be measured and recorded. Natural features, such as rock formations and underground streams, as well as manmade features having a significant effect upon earth resistivity, shall be indicated.

5.1.1.1.3 Minimum Configuration. The basic earth electrode subsystem configuration shall consist of driven ground rods uniformly spaced around the facility and placed 0.6m (2 feet) to 1.8m (6 feet) outside the drip line of structures. The rods shall be interconnected with a 1/0 AWG (American Wire Gage) bare copper cable buried at least .45m (1.5 feet) below grade level. Larger size cables as well as greater burial depths shall be specified where earth and atmosphere considerations so dictate. The interconnecting cable shall be brazed or welded to each ground rod and shall close on itself to form a complete loop with the ends brazed or welded together. (See Figures 1 and 2). Where ground wells are employed, acceptable compression type connectors may be utilized to bond the cable to the ground rod. Coverage of the earth electrode subsystem by asphalt, concrete, etc. shall be kept to a minimum in an effort to maintain the effectiveness of the subsystem. Refer to MIL-HDBK-419 for additional information.

5.1.1.1.3.1 Resistance to Earth. (DO) The resistance to earth of the earth electrode subsystem should not exceed 10 ohms.

5.1.1.1.3.2 Additional Considerations. Where 10 ohms are not obtained with the basic electrode configuration due to high soil resistivity, rock formations, or other terrain features, alternate methods for reducing the resistance to earth shall be considered. For additional information on alternate methods as well as test procedures, see MIL-HDBK-419.

5.1.1.1.4 Ground Rods. Ground rods shall be copper-clad steel, a minimum of 3m (10 feet) in length, spaced apart not more than twice the rod length, and shall not be less than 1.9cm (3/4 inch) in thickness. The thickness of the copper jacket shall not be less than 0.3 mm (0.012 inch).

5.1.1.1.5 Connecting Risers. Provisions shall be made for bonding the lightning down conductors, the connecting cables required by the signal reference and fault protection subsystems, as well as the equipotential plane, to the risers of the earth electrode subsystem.

5.1.1.1.6 Other Underground Metals. Underground metallic pipes entering the facility shall be bonded to an entrance plate and in turn to the earth electrode subsystem with a minimum length of bare 1/0 AWG copper cable whenever such connections are acceptable to both the serving suppliers and the authority having jurisdiction. (See Figure 4). The bond cable shall be welded or brazed to the earth electrode subsystem. Adequate corrosion preventive measures shall be taken. Structural pilings, tanks, and other large underground metallic masses near the periphery of the structure shall be bonded in a like manner to the earth electrode subsystem. (See Figures 1 and 2). Caution shall be used when using clamps to ground metallic gas pipes.

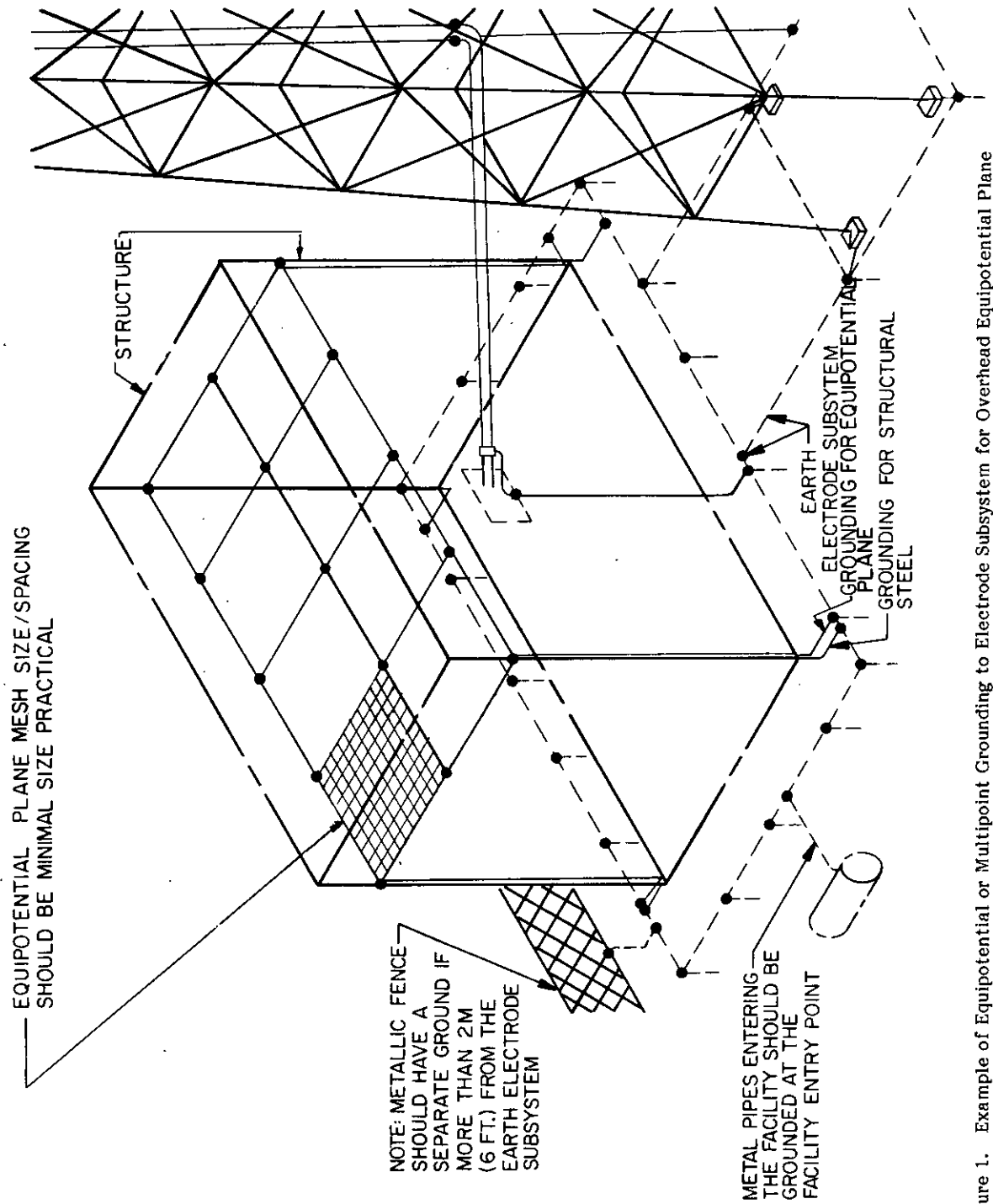

Figure 1. Example of Equipotential or Multipoint Grounding to Electrode Subsystem for Overhead Equipotential Plane

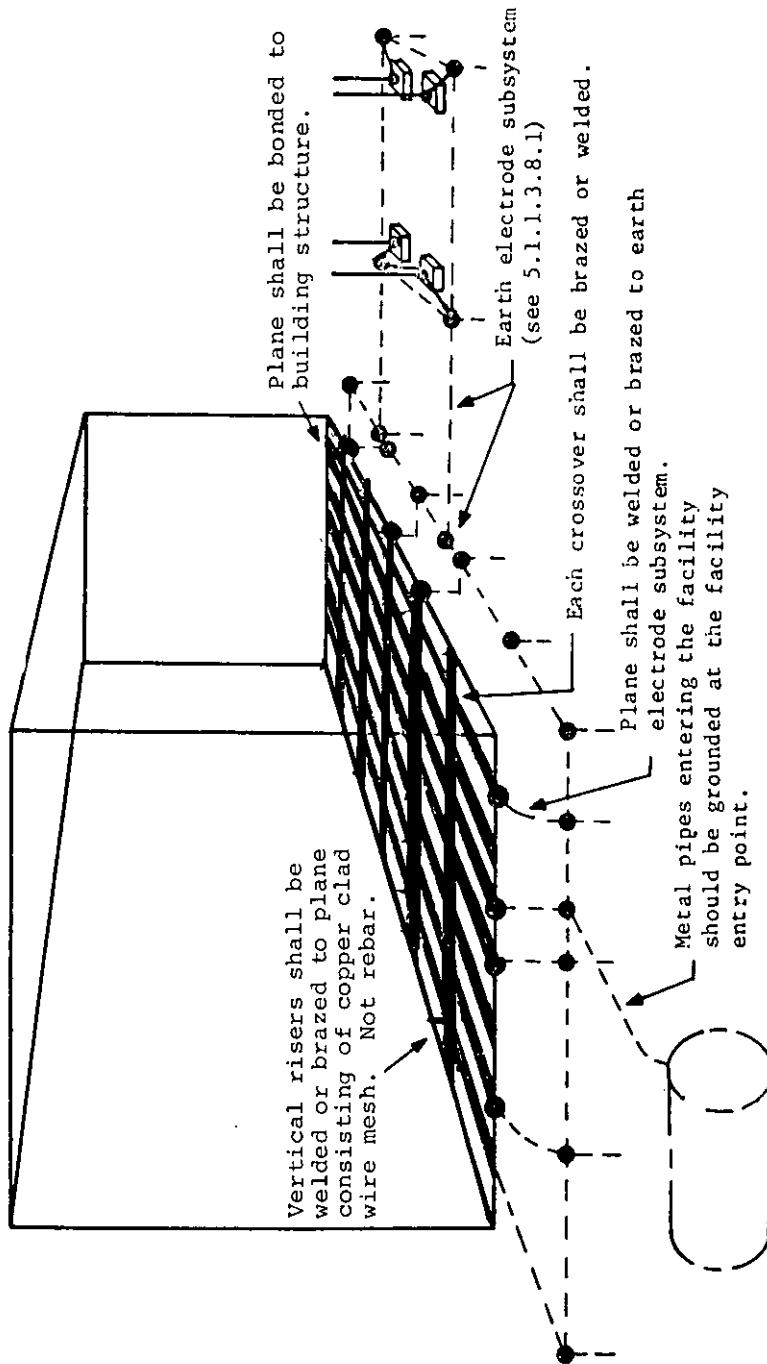

Figure 2. Example of Equipotential Plane to Earth Electrode Subsystem (for New Construction)

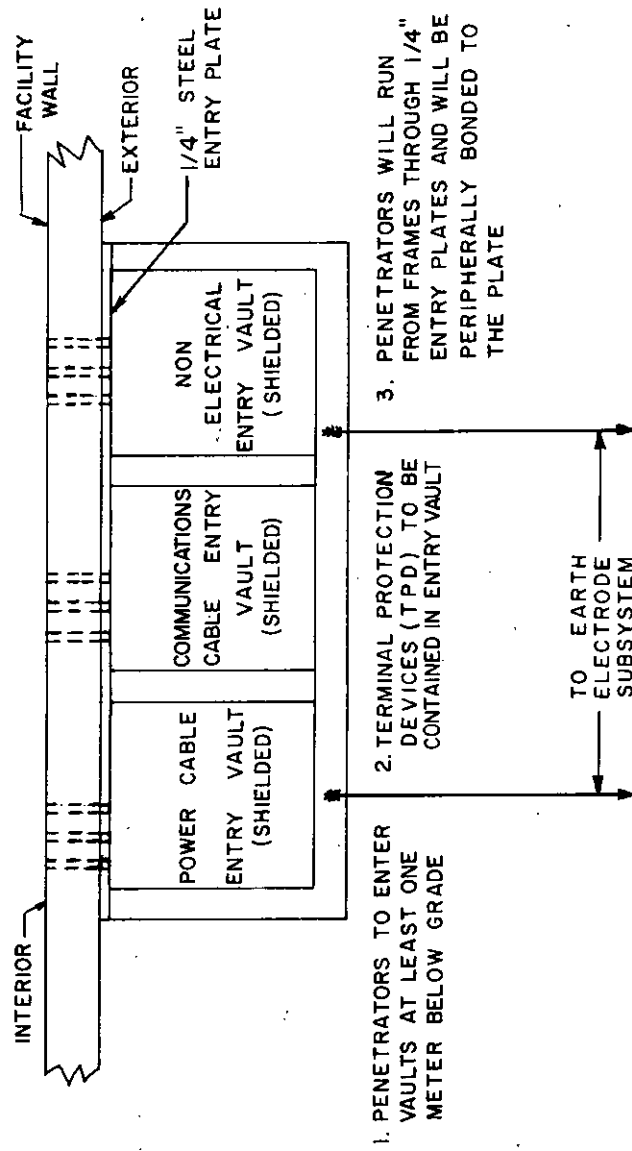

Figure 3. Typical Single Point Entry for Exterior Penetrations (Top View)

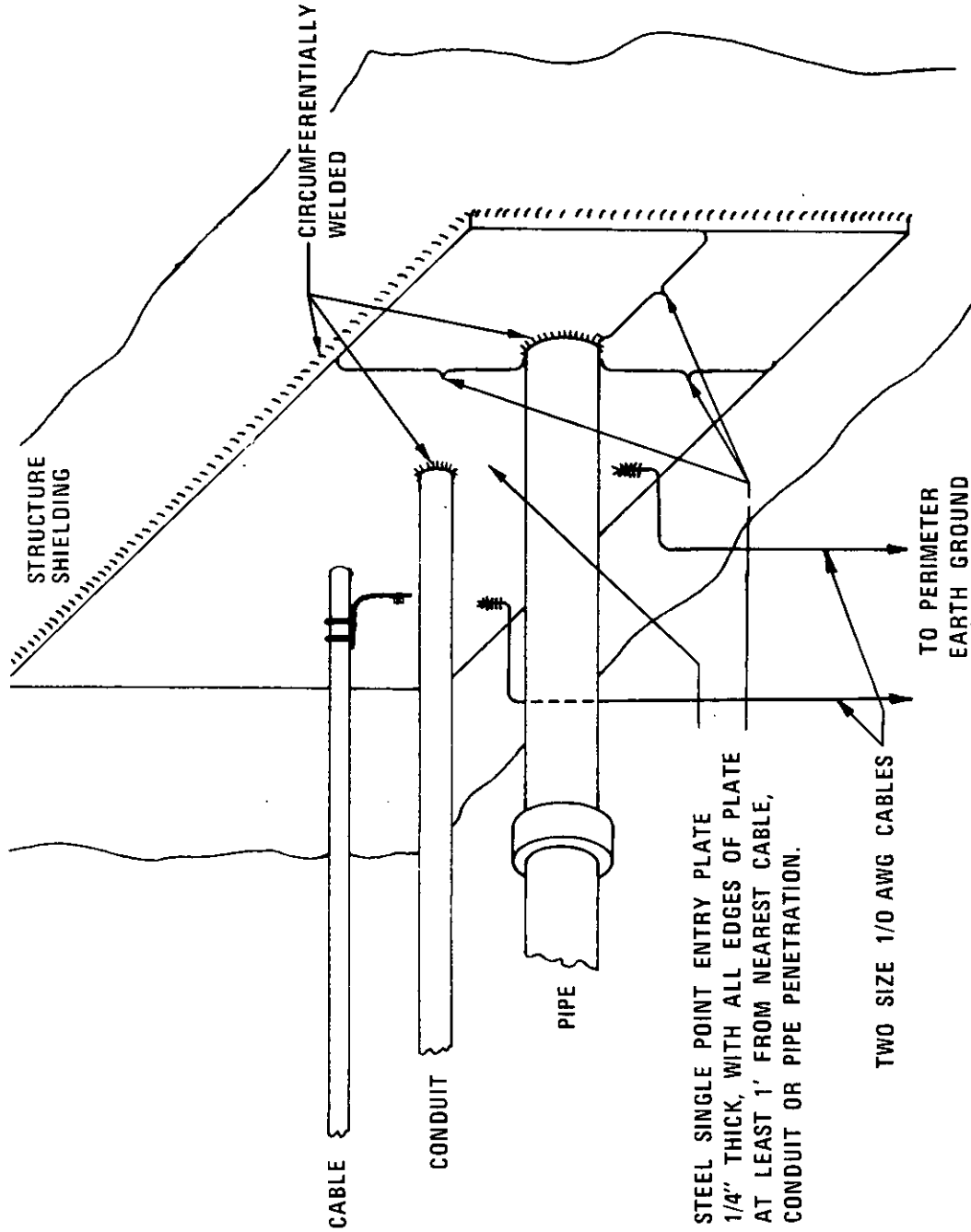

Figure 4. Typical Entry Plate Showing Rigid Cable, Conduit, and Pipe Penetrations

5.1.1.1.7 Resistance Checks. The resistance to earth of the earth electrode subsystem shall be measured only by the fall of potential technique. This shall be accomplished prior to the completion of construction of associated buildings and structures. To assure adequate performance under all climatic conditions, resistance measurements of the earth electrode subsystem to earth will be made at three month intervals for 12 months following installation. The test configuration should be recorded and repeated for each subsequent measurement. The times of such tests shall be chosen so as to demonstrate the adequacy of the earth electrode subsystem over complete ranges of local temperature and precipitation. Ground resistance measurements shall be accomplished every 9 months after the initial 12 month period. For additional test information, see MIL-HDBK-419.

5.1.1.2 Fault Protection Subsystem.

5.1.1.2.1 General. The fault protection subsystem consists of a separate grounding conductor (green wire)¹ to provide personnel and equipment protection against power fault currents and static charge buildup. Protection from lightning flashover shall be provided by grounding all major noncurrent-carrying metal objects, including main structural steel support members. A ground bus shall be provided in all switchboards and panelboards and a separate connecting grounding (green) wire shall be carried within the same raceway or cable with the ac power conductors. The installation shall conform with the requirements of Article 250 of the National Electrical Code. In all areas required to maintain communication security, equipment and power systems shall be grounded in accordance with MIL-HDBK-419.

5.1.1.2.2 Building Structural Steel. All main metallic structural members (except rebar) such as the building columns, wall frames, and roof trusses of steel frame buildings and other metal structures should be made electrically continuous and grounded to the facility ground system. Whenever vertical rebar is utilized to extend the facility ground system, it shall be made electrically continuous and grounded.

5.1.1.2.3 Pipes and Tubes. As required, all metallic piping and tubing and the supports thereof should be electrically continuous and shall be grounded to the facility ground system. See Figure 4.

5.1.1.2.4 Electrical Supporting Structures. Electrical supporting structures shall be electrically continuous and grounded to the facility ground system through the fault protection subsystem.

5.1.1.2.4.1 Conduit. All conduit, whether used for power distribution wiring or for signal and control wiring, shall be grounded in accordance with the following:

a. All joints between sections of conduit, fittings, and buses shall be treated with a conductive lubricant and firmly tightened. Gouging lock nuts shall positively penetrate all paint or other finishes.

b. Cover plates of conduit fittings, pull boxes, junction boxes, and outlet boxes shall be grounded by securely tightening all available screws.

c. Conduit brackets and hangers shall be electrically continuous to the conduit and to the metal structures to which they are attached.

5.1.1.2.4.2 Cable Trays or Raceways. The individual sections of all cable tray systems shall be bonded to each other and to the raceways which they support. All electrically continuous bonds shall be in accordance with the procedures and requirements specified in 5.2 through 5.2.8. All cable tray assemblies shall be connected to ground within 0.6m (2 feet) of each end of the run and at intervals not exceeding 15m (50 feet) along each run.

5.1.1.2.4.3 Wiring System Enclosures. All electrical and electronic wiring and distribution equipment enclosures, not otherwise specifically covered herein, shall be grounded. The grounding conductor shall not penetrate equipment cabinets or cases but rather shall be terminated on a ground stud peripherally welded to the metal barrier.

5.1.1.2.4.4 Metallic Power Cable Sheaths. Metallic cable sheaths on electrical power cables shall be connected to ground at both ends.

1. The grounding conductor (green wire) may be comprised of green, green with yellow stripes, or bare wire with green tape.

MIL-STD-188-124A
2 FEBRUARY 1984

5.1.1.2.5 Electrical Power Systems. All electrical power distribution systems shall be grounded in accordance with the following:

5.1.1.2.5.1 AC Distribution Systems. AC power distribution systems shall have the neutral conductor grounded at the distribution transformer and to the earth electrode subsystem of the facility. The size of the ground conductor from the first service disconnect means to the earth electrode subsystem shall be as specified in Table 1-20 of MIL-HDBK-419 or Table 250-94 of the National Electrical Code. In each facility served by a common distribution transformer, the neutral shall be directly connected to the nearest point of the earth electrode subsystem. Where delta-wye system conversion is employed, the service entrance shall be a five-wire system consisting of three phase conductors, a grounded (neutral) conductor, and a grounding (green) conductor. In each facility, all power distribution neutrals shall be isolated from the C-E equipment case and the structure elements so that no ac return current flows through the equipment and fault protection subsystem or the signal reference network. The fault protection subsystem grounding (green) conductor shall be installed in accordance with the National Electrical Code for all C-E equipment. Conduit shall not be used in lieu of the separate grounding (green) wire.

5.1.1.2.5.1.1 Single Building with Multipower Sources. All grounded (neutral) conductors shall be grounded at the first service disconnect means of each source. For delta-wye conversions, a five-wire system shall be utilized from each source. Delta systems shall employ four-wires from the source, consisting of three phase conductors and a grounding conductor.

5.1.1.2.5.1.2 Multibuildings with Single Power Source. Neutral conductors from multibuildings being serviced from a single commercial power source shall be grounded at the source only. The neutral shall be isolated at the first disconnect means. A five-wire system shall be utilized from the source.

5.1.1.2.5.2 Standby AC Generators. Motor and generator frames and housings shall be grounded in accordance with Article 250 of the National Electrical Code. The generator neutral shall be grounded directly to the earth electrode subsystem. When generators are connected in parallel, the neutrals shall be interconnected and grounded with a single ground conductor.

5.1.1.2.5.3 AC Outlets. The ground terminal of ac outlets shall be connected to the facility ground system with a copper conductor meeting the requirements of Article 250 of the National Electrical Code. The ground terminals in all receptacles on wire mold or plugmold strips shall be hard wired to the equipment ground network. Strips depending upon serrated fingers for grounding shall not be used.

5.1.1.2.5.4 Electrical Motors and Generators. The frames of motors, generators, and other types of electrical rotating machinery shall be grounded to the fault protection subsystem, according to Article 430 of the National Electrical Code.

5.1.1.2.5.5 DC Power Sources. One leg of each dc power system shall be grounded with a single connection directly to the earth electrode subsystem. The size of the grounding conductor shall be as specified by Article 250 of the National Electrical Code. Whether grounded at the source or at a load, a separate current return from load to the source shall be used to assure that no dc current flows in the fault protection or the signal reference subsystem.

5.1.1.2.5.6 Metallic Battery Racks. Metallic battery racks shall also be grounded to the facility ground system at the nearest point.

5.1.1.2.5.7 Ground Fault Circuit Interrupters. Consideration should be given that 120 volt single phase 15 and 20 ampere receptacle outlets have ground fault circuit interrupters (GFCI) for personnel protection. (See NEC Articles 210 and 215).

5.1.1.2.6 Secure Facilities. All areas required to maintain communications security equipment and associated power systems shall be grounded in accordance with MIL-HDBK-419.

5.1.1.3 Lightning Protection Subsystem.

5.1.1.3.1 General. Lightning protection shall be provided as required for buildings and structures in accordance with the National Fire Protection Association (NFPA) No. 78, and the following:

5.1.1.3.2 Buildings and Structures. Lightning protection shall be provided as required for buildings and structures in accordance with the additions and modifications specified herein and the applicable paragraphs of NFPA No. 78. This protection shall be extended to all electrical, electronic, or other elements which are a part of, or are in support of all C-E facilities. Such elements shall include, but shall not be limited to, substations (to the extent that additional protection beyond that provided by the electric utility is necessary), power poles, towers, antennas, masts, etc.

5.1.1.3.3 Down Conductors. Where copper-clad steel down conductors are used on structures not greater than 23m (75 feet) in height, the dc resistance of solid wires or stranded cables shall not be greater than 0.176 ohms per 305m (1000 feet). On structures greater than 23m (75 feet) in height, the dc resistance of the wire or cable shall not be greater than 0.088 ohms per 305m (1000 feet). The size of wires in copper-clad stranded cable shall not be less than No. 14 AWG. (In cases where mechanical and installation situations warrant, a larger (preferably No. 6 AWG copper) wire may be utilized.) The copper covering of all copper-clad steel down conductors shall be permanently and effectively welded to the steel core. The conductivity of copper-clad conductors shall not be less than 30% of a solid copper conductor of equivalent cross-sectional area. Down conductor bends shall not have a radius less than 20cm (8 in) or bends greater than 90 degrees. Any metal object within 1.8m (6 feet) of the lightning downlead shall be bonded to the down conductor (see NEC Article 250). On structures higher than 18m (60 feet) there shall be at least one additional down conductor for each additional 18m (60 feet) of height fractions thereof, except that the interval between down conductors around the perimeters shall not be less than 15m (50 feet) nor greater than 30m (100 feet). Down conductors shall be bonded to the earth electrode subsystem in accordance with 5.1.1.1.5 and 5.2.3.

5.1.1.3.4 Bonding. All bonds between elements of the lightning protection subsystems shall be made by welding or brazing or UL approved high compression clamping devices. Welding or brazing shall be used for all bonds not readily accessible for inspection and maintenance. Soft solder shall not be used for bonding any conductor in the lightning protection subsystem.

5.1.1.3.5 Structural Steel. Substantial metal structural elements of buildings and towers (including overall building shield where it exists) shall be acceptable substitutes for lightning down conductors provided they are permanently bonded in accordance with 5.2 and bonded to the earth electrode subsystem. Bonding straps across all structural joints shall be IAW 5.2.3.3.1.

5.1.1.3.6 Air Terminals (Lightning Rods). Nonmetallic objects, extensions, or protrusions requiring protection shall have the air terminals designed and installed in accordance with requirements of NFPA No. 78, chapters 3-9 and 3-10.

5.1.1.3.7 Guards. Where conductive guards must be used, the guards shall be electrically bonded at each end of the enclosed lightning conductor. Each isolated section of conductive guards shall also be bonded to the lightning conductor.

5.1.1.3.8 Supporting Structures. Lightning protection shall be provided for radar, communications or navigational aid antenna towers, and all other similar supporting structures in accordance with the following:

5.1.1.3.8.1 Earth Electrode Subsystem. An earth electrode subsystem conforming to requirements 5.1.1 through 5.1.1.1.7 shall be provided for all supporting structures. If a tower is adjacent to another structure such that the minimum distance between the tower and the structure is 6m (20 feet) or less, one earth electrode subsystem encompassing both the tower and the other structure shall be provided. For distances greater than 6m (20 feet), separate earth electrode subsystems shall be installed. Two bare 1/0 AWG copper cables shall be used by independent routes to bond the earth electrode subsystem of the tower to the earth electrode subsystem of buildings and structures that have signal, control, or power line interfaces with the tower. (See Figures 1 and 2).

5.1.1.3.8.2 Air Terminals. An air terminal shall be installed on the tower as specified in 5.1.1.3.6. A minimum of two conductive paths shall exist between any two air terminals and between any air terminal and the earth electrode subsystem (except for dead ends less than 5m (16 feet)).

5.1.1.3.8.3 Down Conductors. As a minimum, down conductors shall meet the requirements of 5.1.1.3.3. Each down conductor shall be bonded to the earth electrode subsystem for the tower in accordance with 5.2. For metal towers, where the structural elements are not used as down conductors, the down conductors shall be bonded to the tower legs at the base. Down conductors connecting cables to the earth electrode subsystem shall be protected against mechanical damage. Connecting cables passing through foundations or footings shall be installed in plastic or non-metallic conduit.

MIL-STD-188-124A
2 FEBRUARY 1984

5.1.1.3.8.4 Waveguide Grounding. As a minimum, all waveguides shall be grounded as follows:

a. All waveguides to the antennas shall be grounded at three points: near the antenna, at the vertical-to-horizontal transition near the base of the tower, and at the waveguide entry port.

b. Metallic supporting structures for waveguides shall be electrically continuous and shall be connected to the exterior earth electrode subsystem at the first and last support columns as a minimum. The wire leads shall be as direct as possible.

c. Waveguides shall be grounded with solid copper strap or copper wire at least equal to No. 6 AWG. Braid or fine-stranded wire shall not be used. All bends of ground conductors shall have a radius of 20cm (8 in) or greater and no bends shall be more than 90 degrees.

d. Waveguides shall be properly bonded to the waveguide entrance panel and the panel shall be connected by the most direct route to the earth electrode subsystem using a 1/0 stranded copper cable. For additional information see MIL-HDBK-419.

5.1.1.3.9 Exterior Nonstructural Metal Elements. All exterior hand rails, ladders, stairways, antenna pedestals, and antenna elements operating at ground potential shall be bonded to the lightning protection subsystem with a No. 6 AWG copper wire or larger.

5.1.1.3.10 Exterior Wires and Cables.

5.1.1.3.10.1 Conduit. Corrosion-protected steel conduit shall be used to completely enclose susceptible wiring (notably outdoor or underground signal wiring not otherwise protected) to shield against lightning or lightning induced currents and voltages. Such conduit shall be electrically bonded from section to section with corrosion-protected compression fittings or shall be welded or brazed at each joint. Pull boxes, junction boxes, etc. that are integral to the conduit and electrically bonded to the conduit shall be regarded as conduit. Metal manholes, where used, shall be bonded to the conduit. Nonmetallic manholes shall be bridged to provide a continuous electrical path from one section of conduit to other sections of conduit entering or leaving a manhole. The conduit shall be bonded at each end to the earth electrode subsystem of each terminating facility.

5.1.1.3.10.2 Overhead Guard Wires. Overhead guard wires shall be regarded as air terminals. Such wires shall be spaced not less than 1m (3 feet) above any signal or control circuits being protected. The minimum conductor size shall be 1/0 AWG galvanized steel. Overhead guard wires shall be grounded to the earth electrode subsystem of each terminating facility. When the distance between terminating facilities exceeds 76m (250 feet), the guard wires shall also be bonded to a ground rod meeting the requirements of 5.1.1.1.4 at intervals not exceeding 76m (250 feet). The top of the ground rod shall not be less than 0.3m (1 foot) below grade level.

5.1.1.3.11 Underground Guard Wires. Buried signal, power, or control wires or cables not otherwise protected by ferrous conduit in the manner prescribed by 5.1.1.3.10.1 shall be protected by a bare 1/0 AWG copper guard wire embedded in the soil above and parallel to the wires, cables or ducts. The guard wire shall be laid a minimum of 45cm (18 in) below grade level and at least 25cm (10 in) above the duct or uppermost wire or cable. Where the width of the duct or the spread of the cable run does not exceed 1m (3 feet), one guard wire centered over the duct or cable run shall be installed. Where the spread exceeds 1m (3 feet), two guard wires shall be used. They shall be spaced at least 30cm (12 in) apart and not less than 30cm (12 in) nor more than 46cm (18 in) inside the outermost wires or the edges of the duct bank. All guard wires shall be bonded at each end to the earth electrode subsystem of each terminating facility. The requirement and need for underground guard wires shall be determined by the project engineer and the civil engineer and shall be determined on a case and location basis dependent upon the priority of the circuit and the degree of lightning anticipated.

5.1.1.3.12 Lightning Arrestors. Exposed and underground power lines, not otherwise protected, shall be provided with UL approved lightning arrestors at the point of entrance into the facility. The arrestors shall be installed in accordance with Article 280 of the National Electrical Code.

5.1.1.3.13. Security/Perimeter Fences. All security of perimeter fences shall be grounded IAW procedures outlined in MIL-HDBK-419.

5.1.1.4 Signal Reference Subsystem.

5.1.1.4.1 General. A signal reference subsystem shall be installed at each facility. Signal circuits are grounded to control static charges and noise, and establish a common reference for signals between sources and loads. The desired goal is to accomplish these grounding functions in a manner that minimizes interference between equipments. Where units are distributed throughout the facility, the signal reference ground subsystem shall consist of an equipotential ground plane.

5.1.1.4.2 Higher Frequency Network. Higher frequency networks require an equipotential ground plane. The more extensive the equipotential ground plane, the more effective it is in minimizing differences in potential between interconnected equipments at higher frequencies. This is a departure from the tree-type, single point ground concept formerly used for all types of facilities. The equipotential plane shall be installed under the equipment but, for retrofit, may be installed overhead. (See Figures 1, 2, and 5). Signal, control, and power cables should be routed in close proximity to the equipotential ground plane with the signal and control cables separated from power cables as far as practicable. The equipotential plane shall be connected to the building structure shell and earth electrode subsystem at many points. For additional information see Appendix B and MIL-HDBK-419.

5.1.1.4.3 Lower Frequency Network. A lower frequency network will be installed at facilities employing lower frequency equipments from dc to 30 kHz and in some cases to 300 kHz. The purpose of this network is to isolate lower frequency signals from all other ground networks including structural, safety, lightning and power grounds. This network prevents stray currents (primarily 60 Hz) from developing voltage potentials between points on the ground network. This lower frequency network must be connected to the earth electrode subsystem at one point only (single point) and must be configured to minimize conductor path length. A single point ground however is not viable for lower frequency equipments operating in a higher frequency environment (EMP, lightning, digital systems). Additional information on lower frequency networks can be obtained from MIL-HDBK-419.

5.1.2 Communications-Electronics (C-E) Equipment.

5.1.2.1 Signal Reference Subsystem. This subsystem provides the voltage reference point(s) for all signal grounding.

5.1.2.1.1 Higher Frequency Network. The higher frequency (equipotential) network provides an equal potential plane with the minimum impedance between the associated electronic components, racks, frames, etc. To the extent permitted by circuit design requirements, all reference points and planes shall be directly grounded to the chassis and the equipment case. Direct grounding shall be preferred; however, where individual circuit subassemblies must be floated at a dc potential, capacitive grounding shall be acceptable. Where mounted in a rack, cabinet or enclosure, the equipment case shall be bonded to the rack, cabinet or enclosure, in accordance with 5.2.4. To minimize the voltage differential between points in the higher frequency signal reference network, the dc resistance between any two points within a chassis or equipment cabinet serving as a reference for higher frequency signals shall be less than 1 milliohm (0.001 ohm). The grounding conductor shall not penetrate equipment cabinets or cases but rather shall be terminated on the ground stud peripherally welded to the metal barrier.

5.1.2.1.1.1 Signal Isolation. There shall be no isolation between equipment chassis and case for higher frequency equipments except where stated in 5.1.2.1.1.

5.1.2.1.1.2 Equipment Signal Ground Terminations. Each individual unit or piece of equipment shall either be bonded to its rack or cabinet in accordance with 5.2.4 or shall have its case or chassis bonded to the nearest point of the equipotential plane. Racks and cabinets shall also be grounded to the equipotential plane with a copper strap. All equipment cases and all racks and cabinets shall have a grounding terminal provided that permits convenient and secure attachment of the ground strap.

5.1.2.1.1.3 Shield Terminations of Coaxial and Other Higher Frequency Cables. All connectors shall be of a type and design that provide a low impedance path from the signal line shield to the equipment case. If the signal circuit must be isolated from the equipment case, and if the shielding effectiveness of the case must not be degraded, a connector of a triaxial design that properly grounds the outer cable shield to the case shall be used. Shields of coaxial cables and shielded balanced transmission lines shall be terminated by peripherally grounding the shield to the equipment case. Bonding of connectors shall be in accordance with 5.2.5. Coaxial shields and connector shells shall be grounded at junction boxes, patch panels, signal distribution boxes and other interconnection points along the signal path.

NOTE: Signal and control cables should be separated from power cables as far as practicable.

5.1.2.1.1.4 Overall Shields. Shields surrounding a cable containing individually shielded lower frequency signal lines or containing only unshielded lines shall be grounded at each end and at junction boxes, patch panels, distribution points and at other intermediate points along the cable run. Overall shields shall be grounded to cases, cabinets or conducting surfaces.

MIL-STD-188-124A
2 FEBRUARY 1984

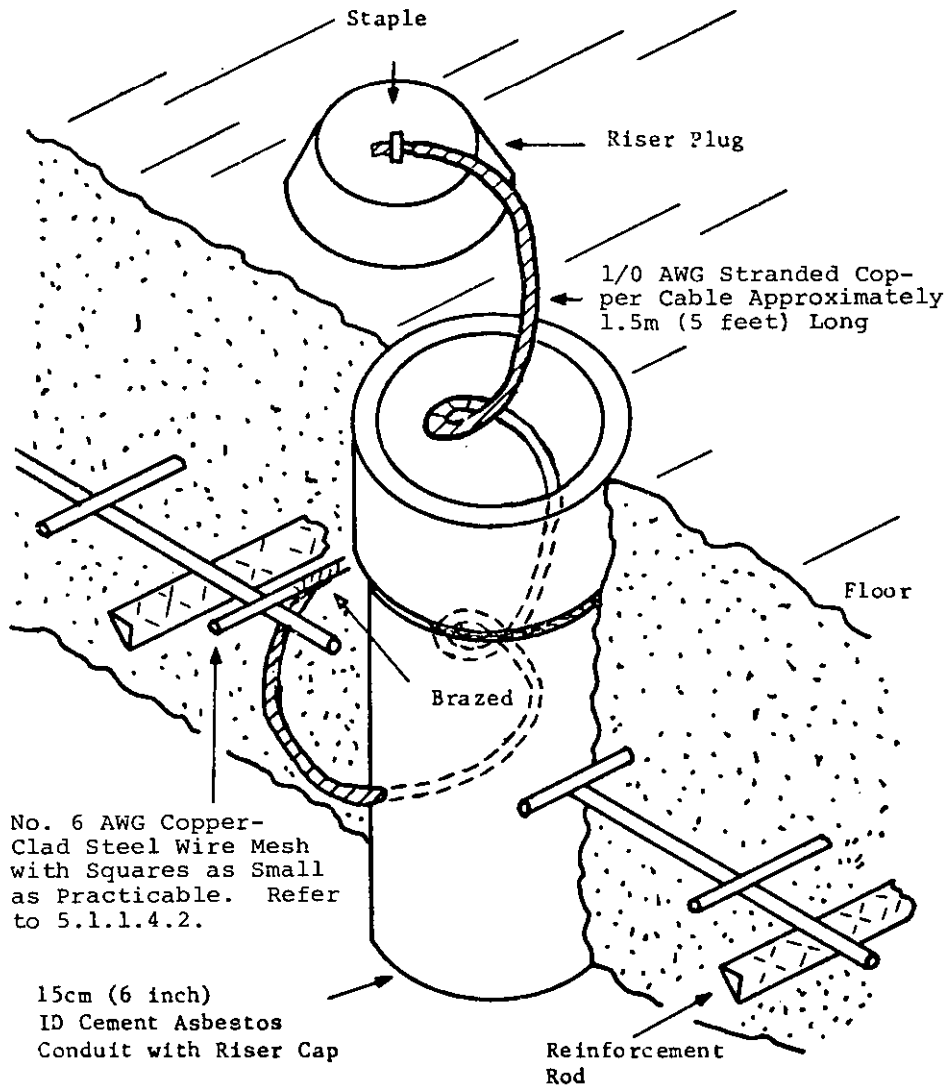

Figure 5. Typical Equipotential Ground Plane for Higher Frequency Facilities Installation (New Construction)

5.1.2.2 Fault Protection Subsystem.

5.1.2.2.1 General. The fault protection subsystem ensures that personnel are protected from shock hazard and the equipment is protected from damage resulting from faults, including short circuits that may develop in the electrical supply and distribution systems. The ac power neutral is isolated from this subsystem throughout the facility except for one point of interface at the power service entry. (See 5.1.1.2).

5.1.2.2.2 Personnel Protection. Means shall be provided by which the equipment parts such as panels, covers, knobs, switches, and connectors that are reasonably subject to human contact during operation and maintenance are grounded to prevent them from becoming electrically energized in case of power line faults or component failures. Ground Fault Circuit Interrupters (GFCI), installed on convenience outlets as specified by 5.1.1.2.5.7 or the National Electric Code Article 215, may be utilized.

5.1.2.2.3 AC Power Neutral. In all electrical and electronic equipment, the ac power neutral (white wire) shall be insulated from the equipment chassis, case, and facility ground system except for one point at the facility power service entry. With the circuit breaker open and the neutral disconnected, a minimum of 1 megohm dc resistance shall exist between either side of the ac line and the equipment case (ground).

5.1.2.2.4 Individual Power Line Filters. All power line filter cases shall be directly bonded in accordance with 5.2 to the equipment case or enclosure.

5.1.2.2.5 Convenience Outlets. The ground terminal of all convenience outlets and plugmolds provided with the equipment or equipment cabinet shall be connected to the fault protection subsystem via the green wire. In addition, the green wire shall be connected to the equipment case and rack. The size of the conductor shall be in accordance with Article 250 of the National Electrical Code. Wire mold or plugmold strips and convenience outlets which depend upon serrated fingers for ground shall not be used.

5.1.2.2.6 Portable Equipment. Portable electrical or electronic equipment cases, enclosures, and housings shall be considered to be adequately grounded for personnel protection through the third wire (grounding) of the power cord provided that continuity is firmly established between the case, enclosure, or housing and the receptacle's ground terminal. The third wire of the power cord shall not be used for signal ground.

MIL-STD-188-124A
2 FEBRUARY 1984

5.2 Bonding. (For Building, Structures, and C-E Equipment Installations).

5.2.1 General. Bonding refers to the process by which a low impedance path for the flow of an electric current is established between two metallic objects. In any realistic electronic facility, whether it is only one piece of equipment or an entire facility, numerous interconnections between metallic objects must be made in order to minimize electric shock hazards, provide lightning protection, establish references for electronic signals, etc. Ideally, each of these interconnections should be made so that the mechanical and electrical properties of the path are determined by the connected members and not by the interconnection junction. Further, the joint must maintain its properties over an extended period of time in order to prevent progressive degradation from subsequent deterioration through corrosion or mechanical looseness.

In terms of the results to be achieved, bonding is necessary for the following reasons:

- a. Protection of equipment and personnel from the hazards of lightning discharges.
- b. Establishment of fault current return parts.
- c. Establishment of homogeneous and stable paths for electrical currents.
- d. Minimization of voltage on enclosures and housings.
- e. Protection of personnel from shock hazards.
- f. Prevention of static charge accumulation.

5.2.2 Surface Platings or Treatments. Surface treatments, including the platings provided for added wearability or corrosion protection, shall offer high conductivity. Plating metals shall be electrochemically compatible with the base metals. Unless suitably protected from the atmosphere, silver and other easily tarnished metals shall not be used to plate the bond surfaces.

5.2.3 Bond Protection. All bonds except those listed in 5.2.3.2 shall be suitably protected against weather, corrosive atmospheres, vibrations and mechanical damage. Under dry conditions, a corrosion preventive or sealant shall be applied with 24 hours of assembly of the bond materials. Under high humidity conditions, sealing of the bond shall be accomplished within one hour of joining.

5.2.3.1 Corrosion Protection. Each bonded joint shall be protected against corrosion by assuring that the metals to be bonded are galvanically compatible. Bonds shall be painted with a moisture proof paint conforming to the requirements of Federal Specification TT-P-1757 or shall be sealed with a silicone or petroleum-based sealant to prevent moisture from reaching the bond area. Bonds which are located in areas not reasonably accessible for maintenance shall be sealed with permanent waterproof compounds. Iridited or other similarly protected bonds shall not require painting to meet the requirements of this standard.

5.2.3.2 Compression Bonds in Protected Areas. Compression bonds between copper conductors or between compatible aluminum alloys and located in readily accessible areas not subject to weather exposure, corrosive fumes or excessive dust shall not require sealing. This is subject to the approval of the responsible civil engineer or the local authorized approval representative.

5.2.3.3 Vibration. Bonds shall be protected from vibration-induced deterioration by assuring that bolts and screws are adequately torqued.

5.2.3.3.1 Bonding Straps. Bonding straps installed across shock mounts or other suspension or support devices shall not impede the performance of the mounting device. They shall be capable of withstanding the anticipated motion and vibrational requirements without suffering metal fatigue or other means of failure. Extra care should be utilized in the attachment of the ends of bonding straps to prevent arcing or other means of electrical noise generation with movement of the strap. NOTE: Bonding straps with a width-to-length ratio approximately 1-to-5 and thickness of approximately 0.76 mm (0.030 in) are better than wires, due to lower inductance per unit length.

5.2.4 Bond Resistance. All bonds for ground conductors whose primary function is to provide a path for power, control or signal currents, and lightning protection shall have a maximum dc resistance of 1 milliohm (0.001 ohm). The resistance across joints or seams in metallic members required to provide electromagnetic shielding shall also be 1 milliohm or less.

5.2.5 Materials. Unless otherwise specified, bonding materials shall be in accordance with 5.2.5.1 through 5.2.6.6.

5.2.5.1 Sweat Solder. Solder used for sweat soldering shall conform to ASTM B 32.

5.2.5.2 Brazing Solder. Brazing solder shall conform to AWS A5.8.

5.2.5.3 Clamps. Where bonding clamps are not avoidable, they shall conform to AN 735 or AN 742.

5.2.5.4 Nuts, Bolts and Washers. Nuts and bolts shall be adequately torqued. Flat washers shall not be surface treated; they shall be plated as specified in 5.2.9 for corrosion control purposes. Star washers smaller than 1.3cm (1/2 in) shall not be used.

5.2.6 Direct Bonds. Wherever possible, the bonding of metallic members to be interconnected shall be accomplished by direct contact of the mating surface without the use of an auxiliary conductor. Electrical continuity is obtained by establishing a fused metal bridge across the junction by welding, brazing, or soldering, or by maintaining a high pressure contact between the mating surfaces with bolts.

5.2.6.1 Welding. Permanent connections between ferrous materials shall be welded whenever required. Welds of sufficient extent to support the load demands on the bonded members shall be considered to provide an adequate electrical bond when the following conditions are met:

a. On members whose maximum dimension is 5cm (2 in) or less, the weld shall extend completely across the side or surface of largest dimension.

b. On members whose largest dimension is greater than 5cm (2 in) but less than 30cm (12 in), one weld of at least 5cm (2 in) in length shall be provided.

c. On members whose largest dimension is greater than 30cm (12 in), two or more welds, each not less than 5cm (2 in) in length, shall be uniformly spaced across the surface of largest dimension. The maximum spacing between successive welds shall not exceed 30cm (12 in).

d. At butt joints, complete penetration welds shall be used on all members whose thickness is 0.6cm (1/4 in) or less. Where the thickness of the members is greater than 0.6cm (1/4 in), the depth of the weld shall not be less than 0.6cm (1/4 in).

e. A fillet weld shall have an effective size equal to the thickness of the members or as specified by AISC Specification S326.

f. At lap joints between members whose thickness is less than 0.6cm (1/4 in), double fillet welds shall be provided.

5.2.6.2 Brazing and Silver Soldering. Brazing or silver soldering shall be acceptable for the permanent bonding of copper and copper alloy materials.

5.2.6.3 Bonding of Copper to Steel. Either brazing or exothermic welding shall be used for the permanent bonding of copper conductors to steel or other ferrous structural members.

5.2.6.4 Soft Soldering. Soft soldering shall not be used for bonding purposes unless:

a. The joint is not subject to mechanical loads and stresses, and

b. The conducting path is not subject to lightning or power fault currents.

5.2.6.4.1 Sweat Soldering. Sweat soldering shall not be used for electrical bonding unless other fasteners such as bolts or rivets are concurrently used to provide mechanical strength, and the requirement of 5.2.6.4 above is met.

5.2.6.4.2 Sheet Metal or Duct Work. Where required, noncurrent-carrying members such as air conditioning and heating ducts, gutter spouts, canopies, awnings, screens, etc., normally held in place or supported with sheet metal screws or mated mechanical joints shall be bonded by soft soldering.

5.2.6.5 Bolting. All bonds utilizing bolts and other threaded fasteners shall be adequately torqued. Inspection shall be conducted periodically. Before joining, all faying surfaces shall be cleaned in accordance with 5.2.8 through 5.2.8.4. Particular care shall be taken to provide adequate corrosion protection to all electrical bonds made with bolts and other threaded fasteners.

5.2.6.6 C-Clamps and Spring Clamps. C-clamps and spring clamps shall not be used for permanent or semipermanent bonding.

5.2.7 Indirect Bonds. Where the direct joining of structural elements, equipments, and electrical paths is impossible or impracticable to achieve, bonding straps or jumpers shall be used.

MIL-STD-188-124A
2 FEBRUARY 1984

5.2.8 Surface Preparation. All mating surfaces which comprise the bond shall be thoroughly cleaned before joining to remove dust, grease, oil, moisture, nonconductive protective finishes, and corrosion products.

5.2.8.1 Area to be Cleaned. All bonding surfaces shall be cleaned over an area that extends at least 0.6cm (1/4 in) beyond all sides of the bonded area on the larger member.

5.2.8.2 Paint Removal. Paints, primers, and other organic finishes shall be removed from the metal.

5.2.8.3 Inorganic Film Removal. Rust, oxides, and nonconductive surface finishes such as anodize shall be removed.

5.2.8.4 Final Cleaning. After initial cleaning with chemical paint removers or mechanical abrasives, the bare metal shall be wiped or brushed with dry cleaning solvent meeting the requirements of P-D-680. Surfaces not requiring the use of mechanical abrasives or chemical paint removers shall be cleaned with a dry cleaning solvent to remove grease, oil, corrosion preventives, dust, dirt, and moisture prior to bonding.

5.2.8.4.1 Clad Metals. Clad metals shall be cleaned with fine steel wool or grit in such a manner that the cladding material is not penetrated by the cleaning process. A bright, smooth surface shall be achieved. The cleaned area shall be wiped with dry cleaning solvent and allow to air dry before completing the bond.

5.2.8.4.2 Aluminum Alloy. After cleaning aluminum surfaces to a bright finish, a brush coating of iridite or other similar conductive coating shall be applied to the mating surfaces.

5.2.8.5 Completion of the Bond. If an intentional protective coating is removed from the metal surface, the mating surfaces shall be joined within 30 minutes after cleaning.

5.2.9 Dissimilar Metals. All mating surface materials that comprise a bond shall be identified. Compression bonding with the use of bolts or clamps shall be utilized only between metals having acceptable coupling values. When the base metals form couples that are not allowed, the metals shall be plated, coated, or otherwise protected with a conductive finish, or a material compatible with each shall be inserted between the two base metals. It shall be constructed from or plated with an appropriate intermediate metal.

5.2.9.1 Corrosion Prevention. Because of galvanic corrosion between dissimilar metals, the welded or brazed joint shall be covered with pitch or other suitable waterproof compound.

5.2.10 Enclosure Bonding. Subassemblies and equipment shall be directly bonded, whenever practical, at the areas of physical contact with the mounting surface.

5.2.10.1 Subassemblies. Subassemblies shall be bonded to the chassis utilizing the maximum possible contact area. All feed-throughs, filters, and connectors shall be bonded to the subassembly enclosure to maintain shield effectiveness. Interference suppression covers shall exhibit intimate contact around their periphery; such contact shall be achieved and maintained through the use of closely spaced screws or bolts, or by the use of resilient gaskets, or both.

5.2.10.2 Equipments. The chassis or case of an equipment shall be directly bonded to the rack, frame, or cabinet in which it is mounted. Adjacent cabinets and racks shall be bonded to each other. Flange surfaces and the contact surface on the supporting element shall be cleaned of all paint or other insulating substances in accordance with the requirements of 5.2.8 through 5.2.8.4. Fasteners shall maintain sufficient pressure to assure adequate surface contact to meet the bond resistance requirements of 5.2.4. Tinnerman nuts and sheet metal screws shall not be used for fasteners. If the equipment must remain operational when partially or completely withdrawn from its mounted position, the bond shall be maintained by a moving area of contact or by the use of a flexible bonding strap. Flexible straps shall be permitted only where necessary to maintain bonding during adjustments or maintenance or when other constraints prevent direct bonding. The grounding conductor shall not penetrate equipment cabinets or cases but rather shall be terminated on the ground stud peripherally welded to the metal barrier.

5.2.11 Connector Mounting. Standard MS-type connectors as well as other shell-type connectors and coaxial connectors shall be mounted so that intimate metallic contact is maintained with the panel on which mounted. Bonding shall be accomplished completely around the periphery of the flange of the connector. Both the flange surface and the mating area of the panel shall be cleaned in accordance with 5.2.8 through 5.2.8.4. After mounting of the connector, the exposed area of the panel shall be repainted or otherwise protected from corrosion in accordance with 5.2.3.1.

5.2.12 Shield Terminations. Cable shields shall be terminated in the manner specified in 5.1.2.1.1.3 and 5.1.2.1.1.4 and tightly fastened to the cable connector shell with a compression or soldered connection. The cable shall be able to withstand the anticipated use without becoming noisy or suffering degradation in shielding efficiency. Coaxial connectors shall be of a material that is corrosion resistant in accordance with requirement 10 of MIL-STD-454. Shield connections shall be kept to less than 2.5cm (1 in) from the point of breakaway from the shielded conductors of the cable.

5.2.13 **RF Gaskets.** Conductive gaskets shall be made of corrosion resistant material, shall offer sufficient conductivity to meet the resistance requirements of 5.2.4 and shall possess adequate strength, resiliency, and hardness to maintain the shielding effectiveness of the bond. The surfaces of contact with the gasket shall be smooth and free of oily films, corrosion, moisture, and paint. The gasket shall be firmly affixed to one of the bond surfaces by screws, conductive cement, or other means which do not interfere with the effectiveness of the gasket. The gaskets may be placed in a milled slot to prevent lateral movement when the bond is disassembled. Gaskets shall be a minimum of 3mm (1/8 in) wide. The gasket, as well as the contact surfaces, shall be protected from corrosion.

5.3 Shielding.

5.3.1 **General.** Groups of equipment or subsystems may be made electromagnetically compatible by any combination of three fundamental approaches: (1) the interfering signal source may be reduced, (2) the receptor susceptibility may be reduced, or (3) the attenuation of the path or paths over which interference is transmitted from source to receptor may be increased. Radiated interference signals generated by electromagnetic fields may be effectively attenuated by electromagnetic shielding, either at the source or at the receptor. Shielding, when properly designed and implemented, offers significant wideband protection against electromagnetic radiation, where source and receptor are not sufficiently separated for adequate free space radiation attenuation. It is relatively easy to obtain 40 dB of shielding effectiveness in a frequency range above 100 kHz with a single shield, and values as high as 70 dB can be obtained with careful single-shield construction. Where this is inadequate, double shields are normally used, providing shielding values as high as 120 dB.

Radiated energy may still be coupled into a susceptible device through a shield of inadequate thickness, through holes penetrated for ventilation and other purposes, and through imperfectly jointed shielded sections. Precise calculation of shielding effectiveness, even for perfectly joined solid shields, depends on the form of the shield and the type of field for which the shielding is to be used. Both electric and magnetic coupling can occur. Normally, it is relatively easy to provide electric shielding. Magnetic shielding, however, is more difficult to provide, particularly at frequencies below 100 kHz.

5.3.1.1 **Basic Shielding Requirements.** The C-E equipment shall meet the applicable electromagnetic susceptibility and emission requirements of MIL-STD-461. Additionally, where required, the equipment shall incorporate shields required to protect personnel from high level electromagnetic fields and X-rays which may be intentionally or unintentionally generated by the equipment.

5.3.1.2 **Shielded Enclosures.** Shielded enclosures shall only be specified when a requirement is established as a result of power density predictions or measurements and equipment susceptibility/radiation evaluations.

5.3.2 **Electromagnetic Interference (EMI) Control.** Shielding shall be integrated with other basic interference control measures such as filtering, wire routing, cable and circuit layout, signal processing, spectrum control, and frequency assignment to achieve operational compatibility of the equipment. The degree of shielding shall be determined by the systems engineering process.

5.3.2.1 **Materials.** Shields shall be constructed from material that provides the required degree of signal suppression without incurring unnecessary expense and weight. The selection of materials shall be based upon the following: the amplitude and frequency of the signals to be attenuated, the characteristics of the electromagnetic field of the signal (i.e., is the signal being coupled via inductive, capacitive, or free space means), configuration, the installation constraints, and the corrosion properties.

5.3.2.2 **Gaskets.** Conductive gaskets conforming to 5.2.13 shall be utilized at joints, seams, access covers, removable partitions, and other shield discontinuities to the extent necessary to provide interference-free operation of the equipment under normal use and environmental conditions. Finger stock used on doors, covers, or other closures subject to frequent openings shall be installed in a manner that permits easy cleaning and repair.

5.3.2.3 **Filter Integration.** Filters on power, control, and signal lines shall be installed in a manner that maintains the integrity of the shield. Power line filters shall be completely shielded with the filter case grounded in accordance with 5.2.10. Filters on power control and signal lines shall be placed as close as possible to the point of penetration of the case in order to avoid long, unprotected paths inside the equipment.

MIL-STD-188-124A
2 FEBRUARY 1984

5.3.2.4 Control of Apertures. Unnecessary apertures shall be avoided. Only those shield openings needed to achieve proper functioning and operation of the equipment shall be provided.

a. Controls, switches, and fuse holders shall be mounted such that close metal-to-metal contact is maintained between the cover or housing of the devices and the case.

b. Where nonconductive control shafts are necessary, a waveguide-below-cutoff metal sleeve (for the highest frequency of concern) shall be peripherally bonded to the case for the shaft.

c. The cutoff frequency for the waveguide shall be considerably higher than the equipment operating frequency. The length of the sleeve shall be no less than three times its diameter.

d. Pilot lights shall be filtered or shielded as needed to maintain the required degree of shielding effectiveness.

e. If possible, ventilation and drainage holes shall not penetrate RF compartments. If necessary, such holes shall utilize waveguide-below-cutoff honeycomb or other appropriate screening. Care shall be taken to assure the honeycomb and screens are well bonded to the shield completely around the opening. For additional information see MIL-HDBK-419.

5.3.2.5 Wire and Cable Routing. The routing and layout of wires and cables shall be performed in a manner that does not jeopardize the integrity of the equipment shield. Cables or wires carrying high level signals shall be routed as far as feasible from low level signal lines. Power lines and control lines subject to large transients shall be routed away from sensitive digital or other susceptible circuits.

5.3.2.6 Telephone Cable Shields. The shields of all telephone cables entering a C-E facility must be bonded to each other and to the earth electrode subsystem through the steel entry plate. This measure eliminates harmful differences of potential between the various telephone cables entering the facility. It is important that electrical continuity of all cable shields is maintained. Care must be taken to ensure that shields of aerial telephone cables are bonded to any connecting buried or underground cable shields. This provides a path to ground for lightning and power currents and provides an effective noise shield.

MIL-STD-188-124A
2 FEBRUARY 1984

Custodians:
Army - SC
Navy - EC
Air Force - 90

Review Activities:
Army - CR
Navy - AS, MC, OM
Air Force - 1, 80, 89,
NSA-NS, DCA-DC, TRI-TAC-TT,
DIA-RCM-4

Other Interest:
DNA - DS

Preparing Activity:
Air Force - 90

Agent:
Air Force - 90

Civil Engineering Coordinating Interest:
FAA - ARD-350

(Project SLHC 1240)

Activity Assignee:
Air Force - 90

Project SLHC

MIL-STD-188-124A
2 FEBRUARY 1984

APPENDIX A

MEMORANDUM FROM THE UNDER SECRETARY OF DEFENSE,
RESEARCH AND ENGINEERING; 16 AUGUST 1983, STANDARDS IN
THE MIL-STD-188 SERIES

This Appendix contains information related to MIL-STD-188-124.
Appendix A is a mandatory part of this standard.

MIL-STD-188-124A



RESEARCH AND
ENGINEERING

THE UNDER SECRETARY OF DEFENSE
WASHINGTON, D.C. 20301

16 AUG 1983

MEMORANDUM FOR ASSISTANT SECRETARY OF THE ARMY (INSTALLATIONS, LOGISTICS &
FINANCIAL MANAGEMENT)
ASSISTANT SECRETARY OF THE NAVY (SHIPBUILDING & LOGISTICS)
ASSISTANT SECRETARY OF THE AIR FORCE (RESEARCH DEVELOPMENT
& LOGISTICS)
COMMANDANT OF THE MARINE CORPS
DIRECTOR, DEFENSE COMMUNICATIONS AGENCY
DIRECTOR, NATIONAL SECURITY AGENCY

SUBJECT: Mandatory Use of Military Telecommunications Standards in the
MIL-STD-188 Series

On May 10, 1977, Dr. Gerald Dinneen, then Assistant Secretary of Defense(C3I), issued the following policy statement regarding the mandatory nature of the MIL-STD-188 series telecommunications standards:

"...standards as a general rule are now cited as 'approved for use' rather than 'mandatory for use' in the Department of Defense.

This deference to the judgment of the designing and procuring agencies is clearly appropriate to standards dealing with process, component ruggedness and reliability, paint finishes, and the like. It is clearly not appropriate to standards such as those in the MIL-STD-188 series which address telecommunication design parameters. These influence the functional integrity of telecommunication systems and their ability to efficiently interoperate with other functionally similar Government and commercial systems. Therefore, relevant military standards in the 188 series will continue to be mandatory for use within the Department of Defense.

To minimize the probability of misapplication of these standards, it is incumbent upon the developers of the MIL-STD-188 series to insure that each standard is not only essential but of uniformly high quality, clear and concise as to application, and wherever possible compatible with existing or proposed national, international and Federal telecommunication standards. It is also incumbent upon the users of these standards to cite in their procurement specifications only those standards which are clearly necessary to the proper functioning of the device or systems over its projected lifetime."

This statement has been reviewed by this office and continues to be the policy of the Department of Defense.

APPENDIX B

DISCUSSION OF SIGNAL GROUND SYSTEMS

1.0 **General.** There are three basic methods by which signal reference subsystems of electronic equipments can be grounded. However, due to personnel hazards, only two of these methods are generally utilized.

- a. Equipotential Plane
- b. Single point ground system (for use at lower frequencies)¹
- c. Multipoint ground system (for use at higher frequencies)²

While the cable or bus to the single point ground offers the most effective low impedance path for lower frequency signals, its impedance at higher frequencies prevents it from being an effective ground at frequencies above 300 kHz. In some instances, it may even be an ineffective ground at frequencies above 30 kHz. A single wire ground bus, even though terminated in zero impedance, assumes the characteristics of a single wire unbalanced transmission line. The impedance of such a line can be calculated by taking into account such parameters as length, height above ground (radiation effects) and finite earth conductivity. Since one end of the ground bus is not terminated, it can be accurately represented as an open-ended transmission line.

From this, it can be assumed the impedance of the grounding system is very high throughout the frequency spectrum, except in very narrow frequency ranges where the impedance changes signs. Consequently, a ground distribution system which performs adequately for dc or lower frequencies presents an entirely different characteristic at higher frequencies.

1.1 **Single Point Ground System.** In the single point ground system, as the name implies, all signal circuit grounds are referenced to a single point; this reference ground is then connected to the facility ground or a special ground connection provided for this purpose. In a cabinet, all electronic circuits (including the chassis) are bonded to a ground which is isolated from the cabinet and are then bonded to the one reference point. This isolates the cabinet and prevents any conducted, circulating currents in the facility ground from producing potential (noise) drops within the equipment. Conversely, no conducted circulating currents are introduced into the facility ground from the cabinets. Ground currents can produce voltage drops within the facility ground which can be a source of interference although, because of the generally small magnitude, not enough to cause the signal-to-noise ratio to become intolerable.

The paths of copper that connect the single reference point become longer as the systems become larger and begin to generate appreciable unavoidable ground loops which, in turn, increase the magnitude of the noise. The effectiveness of this type of system must then be weighed against other possible solutions.

1.2 **Equipotential Ground System.** The equipotential plane shall be bonded to the earth electrode subsystem at multiple points. Such an equipotential plane exists in a building with a metal floor or ceiling grid electrically bonded together, or in a building with a concrete floor with a ground grid imbedded in it, connected to the facility ground. Equipment cabinets are then connected to the equipotential plane. Chassis are connected to the equipment cabinets and all components, signal return leads, etc., are connected to the chassis. The equipotential plane is then terminated to the earth electrode subsystem to assure personnel safety and a low impedance path to ground.

-
- 1 Lower frequencies - includes all voltages and currents whether signal, control, or power from dc to 30 kHz and may extend up to 300 kHz depending on the electromagnetic and physical aspects of the equipment, subsystem, and/or facility involved. (Audio and tone signaling devices operate in the lower frequency ranges).
 - 2 Higher frequencies - includes all voltages and currents whether signal or control down to 300 kHz and may extend lower to 30 kHz, depending on the electromagnetic and physical aspects of the equipment, subsystem, and/or facility involved. (Digital equipments, i.e., teletype, data, and other binary signaling devices operate at higher frequencies). All military communication stations are treated as higher frequency facilities.

At high frequencies, the large conducting surface embedded in or on the floor under the equipments to be grounded, presents a much lower characteristic impedance than a single wire, even if both were improperly terminated. This is true because the characteristic impedance (Z_0) is a function of L/C . As capacity to earth increase, Z_0 decreases.

Normally, the capacity of a metallic sheet to earth is higher than that of wire. If the size of the sheet is increased and allowed to encompass more area, the capacitance increases. Also, the unit length inductance decreases with width, which further decreases Z_0 . If the dimensions of a metallic sheet increase extensively (as in the case of a conducting subfloor), the characteristic impedance approaches a very low value. In this case, even if improperly terminated, the impedance would be quite low throughout a large portion of the spectrum. This, in turn, would establish an equipotential reference plane for all equipments bonded to it. With this reference plane bonded to earth, the following advantages are obtained:

- a. Any "noisy" cable or conductor connected to the receptor through or along such a ground plane will have its field contained between the conductor and the ground plane. The noise field can be "shorted out" by filters and bond straps because the distance between these "transmission line" conductors is very small. Shorting out the noise field has the desirable effect of keeping noise current from flowing over the receptor case and along any antenna input cables.
- b. Filters at the interface terminals of equipment can operate more effectively when both terminals of their equivalent "transmission line" are available. As in a, above, a large conducting surface makes it possible to contain the field carried by the offending conductor in such a way that it can be more easily prevented from traveling further.
- c. A large conducting surface will also tend to shield any rooftop antennas from cable runs below it.

1.2.1 Equipotential Plane. The equipotential plane may be a solid sheet or may consist of a wire mesh. A mesh will appear electrically as a solid sheet as long as the mesh openings are less than $1/8 \lambda$ at the highest frequencies of concern. When it is not feasible to install a fine mesh (either overhead or under the equipment) a larger grid may be installed, but even then the mesh size should be made as small as practicable. In all cases, the "Design Objective" (DO) is to keep the mesh size to less than $1/8\lambda$ at the highest frequencies of concern.

1.2.2 Types of Equal Potential Planes. Conducting media that can be utilized for ground distribution networks are Q-cell floor (if available) or subfloor of aluminum, copper, or sheet metal laid underneath the floor tile.

Since a large solid conducting surface may not be economically feasible for some installations, a ground reference plane, made up of a copper grid, should be considered. Copper-clad steel wire meshes with all crossovers brazed are commercially available. They are obtainable in mesh spacings of from 5 to 61cm (2 to 24 in) squares, in AWG wire sizes Nos. 6, 8, 10, and 12. It is normally furnished in 3.7m (12 foot) rolls, but can be obtained in various widths up to 5.5m (18 feet). Ground connections can be made up to the grid by direct bonding or manufactured ground "buses" that are connected to the grid and give grounding access at the floor surface. Normally, if the grid is embedded in a concrete floor, the latter method provides the easiest grounding source. Equipotential planes for existing facilities may be installed at/near the ceiling above the C-E equipment. All equipotential planes should be bonded to the facility ground system and the earth electrode subsystem.

INSTRUCTIONS: In a continuing effort to make our standardization documents better, the DoD provides this form for use in submitting comments and suggestions for improvements. All users of military standardization documents are invited to provide suggestions. This form may be detached, folded along the lines indicated, taped along the loose edge (*DO NOT STAPLE*), and mailed. In block 5, be as specific as possible about particular problem areas such as wording which required interpretation, was too rigid, restrictive, loose, ambiguous, or was incompatible, and give proposed wording changes which would alleviate the problems. Enter in block 6 any remarks not related to a specific paragraph of the document. If block 7 is filled out, an acknowledgement will be mailed to you within 30 days to let you know that your comments were received and are being considered.

NOTE: This form may not be used to request copies of documents, nor to request waivers, deviations, or clarification of specification requirements on current contracts. Comments submitted on this form do not constitute or imply authorization to waive any portion of the referenced document(s) or to amend contractual requirements.

☆ U.S. Government Printing Office: 1982-360-979/5804

(Fold along this line)

(Fold along this line)



NO POSTAGE
NECESSARY
IF MAILED
IN THE
UNITED STATES

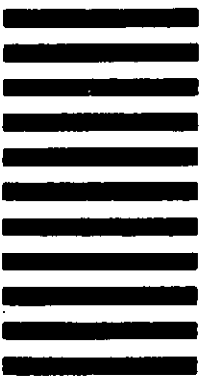

OFFICIAL BUSINESS
PENALTY FOR PRIVATE USE \$300

BUSINESS REPLY MAIL
FIRST CLASS PERMIT NO. 73236 WASH DC

POSTAGE WILL BE PAID BY HQ U.S. AIR FORCE

Commander 1842 EEG
Attn: EEITE
Scott AFB IL 62225

STANDARDIZATION DOCUMENT IMPROVEMENT PROPOSAL

(See Instructions – Reverse Side)

1. DOCUMENT NUMBER MIL-STD-188-124A		2. DOCUMENT TITLE Grounding, Bonding and Shielding	
3a. NAME OF SUBMITTING ORGANIZATION		4. TYPE OF ORGANIZATION <i>(Mark one)</i> <input type="checkbox"/> VENDOR <input type="checkbox"/> USER <input type="checkbox"/> MANUFACTURER <input type="checkbox"/> OTHER <i>(Specify):</i> _____	
b. ADDRESS <i>(Street, City, State, ZIP Code)</i>			
5. PROBLEM AREAS			
a. Paragraph Number and Wording:			
b. Recommended Wording:			
c. Reason/Rationale for Recommendation:			
6. REMARKS			
7a. NAME OF SUBMITTER <i>(Last, First, MI)</i> – Optional		b. WORK TELEPHONE NUMBER <i>(Include Area Code)</i> – Optional	
c. MAILING ADDRESS <i>(Street, City, State, ZIP Code)</i> – Optional		8. DATE OF SUBMISSION <i>(YYMMDD)</i>	

(TO DETACH THIS FORM, CUT ALONG THIS LINE.)